

M500 SERIES

M500 DROP-IN STYLE

Specify "STD" when ordering

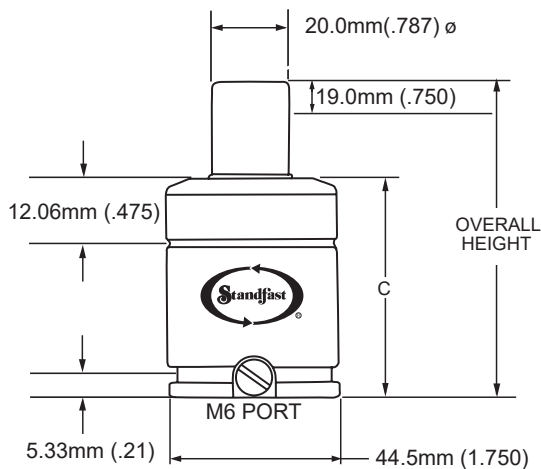

M500 TAPPED BASE STYLE

Specify "TB" when ordering

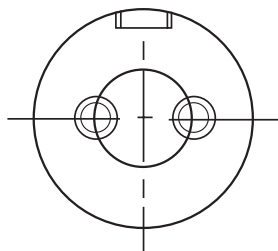

M8 X 1.25 TAP 6.00mm DEEP
2 PLACES 20mm (.787)Ø B.C.

M500 STUD MOUNT STYLE

Specify "STUD" when ordering

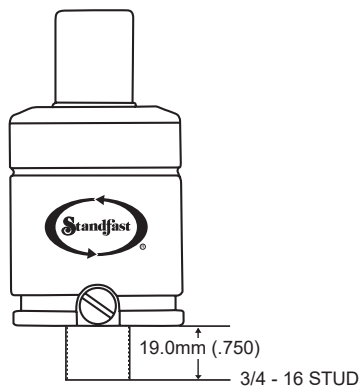

Our M500 is the first cylinder to be offered by Standfast Industries with a 44.5mm (1.75") body diameter.

To adjust pressure on the M500 cylinder, please use a CAM6R Charging Adapter and a DTM6R Discharge Tool.

We recommend that all cylinders be backed-up during operation.

The M500 may be hoses into a system using our Micro-Line miniature hose assemblies and fittings.

M500 STROKE CHART

STROKE LENGTH		MAX.ALLOW. STROKE		C		OVERALL LENGTH		WEIGHT
MM	INCHES	MM	INCHES	MM +/- .5	INS +/- .02	MM +/- .5	INS +/- .02	IN LBS.
* 13.0	0.492	10.0	0.393	44.5	1.752	57.0	2.244	1.0
19.0	0.748	16.0	0.630	51.0	2.008	70.0	2.756	1.1
* 25.0	0.976	22.0	0.866	56.8	2.236	81.6	3.212	1.2
* 32.0	1.220	29.0	1.141	63.0	2.480	94.0	3.701	1.3
* 38.0	1.476	35.0	1.378	69.5	2.736	107.0	4.212	1.4
50.0	1.969	47.0	1.850	82.0	3.228	132.0	5.197	1.5
* 63.0	2.461	60.0	2.362	94.5	3.720	157.0	6.181	1.7
75.0	2.953	72.0	2.834	107.0	4.212	182.0	7.165	1.9
80.0	3.150	77.0	3.031	112.0	4.409	192.0	7.559	2.0
100.0	3.937	97.0	3.819	132.0	5.197	232.0	9.133	2.3
125.0	4.921	122.0	4.803	157.0	6.181	282.0	11.102	2.6

Recommended tolerance on machined pocket in the die is 46.5/48.5(1.83"/1.91") for maximum M500 performance

* Please note: Millimeter value for these stroke lengths is rounded. Inch value indicates actual stroke length.

M500 FORCE CHART based on 2,000 psi/138 Bar

Initial contact force for the M500 is 973 lbs.

STROKE		TRAVEL											
MM	INCHES	13.0	19.0	25.0	32.0	38.0	50.0	63.0	75.0	80.0	100.0	125.0	
13.0	0.51	1161											
19.0	0.75	1120	1205										
25.0	0.98	1093	1161	1237									
32.0	1.26	1072	1126	1186	1265								
38.0	1.50	1059	1105	1156	1221	1284							
50.0	1.97	1041	1077	1115	1164	1209	1311						
63.0	2.48	1028	1057	1087	1125	1160	1237	1332					
75.0	2.95	1020	1044	1070	1101	1130	1192	1267	1346				
80.0	3.15	1017	1040	1064	1094	1120	1178	1247	1318	1350			
100.0	3.94	1008	1027	1046	1069	1090	1135	1187	1240	1263	1366		
125.0	4.92	1001	1016	1032	1050	1066	1101	1141	1180	1197	1272	1379	

Formula to calculate charge pressure for lower initial contact pressure is: FORCE REQUIRED x 2.055 (ex. 600 x 2.055 = 1233 psi charge in cylinder).

PLEASE NOTE: A max. charge pressure of 2175 PSI/150 Bar is available upon request. Initial contact force at 2175 PSI/150 Bar will be 1059 lbs (471 daN).

ORDERING CODE: M500 X STROKE LENGTH - MOUNT STYLE - CHARGE PRESSURE